



MotoSafe®

MSE of Canada Ltd.

INSULATION MONITOR FOR LOW VOLTAGE ELECTRICAL MACHINES TYPE MG600 MODEL M603IND

MotoSafe Type MG600 Model M603IND Insulation Monitors are designed for use in industrial applications to monitor AC or DC motors with line voltages to 600 volts. The range of insulation resistance covered - 5 Megohms to 1 Megohm - was chosen to meet the general requirements of industrial environments. They provide a visual alarm indication, with contacts for external alarm and other functions.

FEATURES:

- ◆ Easy Installation
- ◆ Small footprint DIN Rail Mounting
- ◆ Completely automatic in operation
- ◆ Early warning of insulation problems
- ◆ Solid state circuitry
- ◆ Low monitoring voltage for personnel safety
- ◆ Integral self-test capability
- ◆ LED local alarm
- ◆ Contacts provided for local alarm and PLC connection
- ◆ Optional automatic reset mode

APPLICATION:

MotoSafe Model M603IND Insulation Monitors provide safe monitoring of electrical motor insulation integrity in all environments. Their primary application is on motors, which are in intermittent operation, as these motors are the most susceptible to insulation deterioration in adverse environments. The device designed for use on motors or generators up to 600 volts AC or DC on grounded or ungrounded power systems. MotoSafe Model M603IND Insulation Monitors give **early warning** of insulation degradation long before the motors are in danger of failing on start up. This allows preventative maintenance to be scheduled when convenient, thus eliminating motor insulation failure as a cause of production downtime, product loss or emergency situations.

Model M603IND offers easy meggering of the motor winding and has three alarm levels (5, 3 and 1 M Ω), selectable with a faceplate switch, to provide a simple way of insulation deterioration rate determination by noting the time intervals between alarms at successively lower levels.

Model M603IND monitors are designed to monitor insulation resistance to 10M Ω . For higher settings the MotoSafe Model LM602IND is recommended with low voltage motors.



ORDERING INFORMATION:

- Order MotoSafe Model M603IND and specify the required control voltage.
- Installation Kit IK-MGM includes: the bracket DIN-MGM, the flashing alarm light FAL, a Test Resistor and hook-up wire, wire connectors, Ty-wraps and mounting screws to install the unit, Explanatory and Warning labels.

SPECIFICATIONS

Model M603IND

Max Line Voltage	600 AC/DC
Supply Voltage*	115 or 230v. AC, +20 -40% 50/60 Hz
Power Requirements	3 VA
Factory Set point**	5, 3 & 1 Megohms
Isolation Voltage	24 – 600V AC/DC
Isolation time	0.5 ms
Contact Rating	5 amp., 250 v. AC resistive
Dimensions (mm) WxHxL (in)	45 x 68 x 112 1.77 x 2.67 x 4.4
Weight (kg)/(oz)	0.27/9.5

* DC and 400Hz supply voltages available – contact factory.

** For other set points, consult factory.

- Maximum short circuit current 5 microamps.

- Operating temperature -20°C to +50°C;
storage temperature -40°C to +100°C.

- Environment; maximum 95% relative humidity,
non-condensing.

- UL and CSA Approved as Industrial Control devices.

CONNECTION DIAGRAM – MODEL M603IND

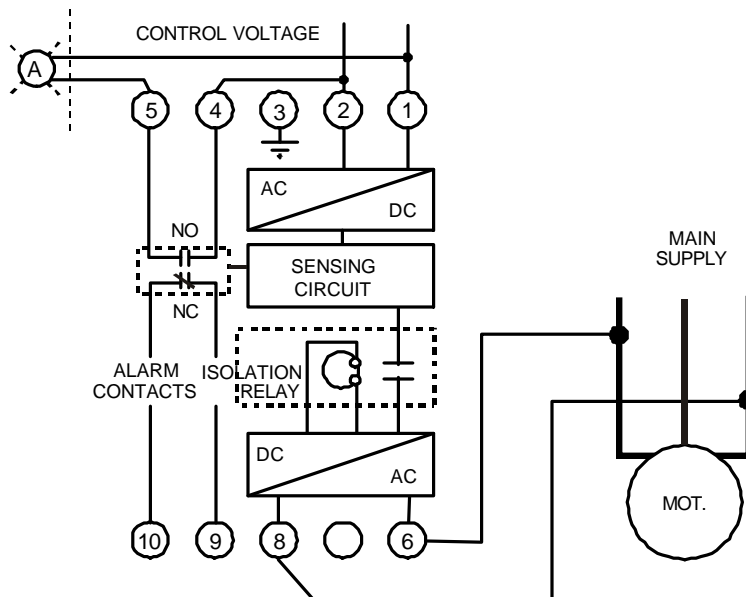

MotoSafe™ MONITOR TYPE M603IND; INSTALLATION

IMPORTANT: READ THE FOLLOWING INSTRUCTIONS BEFORE INSTALLING THE MONITOR!

The MotoSafe device continuously monitors the insulation resistance of idle machines to provide early warning of insulation deterioration. It withstands test voltages up to 1000V.

INSTALLATION

1. Disconnect power from the starter unit.
2. Install the mounting bracket close to the enclosure hinges using the screws supplied. Clip the monitor securely to the mounting bracket.
3. If required and regulations permit, install the long life flashing alarm light (supplied) on the starter enclosure front panel close to the hinges and affix the self-adhesive warning label around the lamp.
4. Connect terminals 1 & 2 to the specified control voltage. Connect terminal 3 to ground.
5. Connect terminals 6 & 8 to any two motor phases on the load of the main contactor.

Use terminals 9 & 10 for start prevention (if required) and terminals 4 & 5 for local or remote alarm operation.

INITIAL TEST PROCEDURE

1. Ground one of the motor phases momentarily with the supplied Test Resistor
2. The Red LED should light and the external alarm circuit be activated after a delay of 8 – 10 seconds.
3. Reset the monitor with the RESET button.
4. Repeat the procedure with the other two phases.

Monitoring is now automatic and may be verified at any time by pressing the TEST button.

CONNECTION DIAGRAM MODEL M603IND

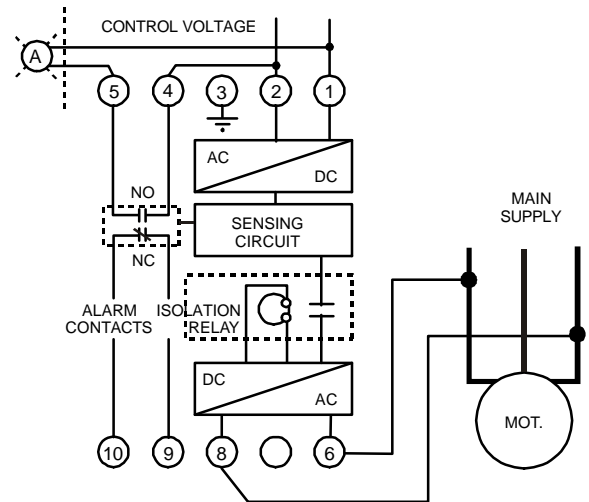

NB. If the motor is wired for start prevention it will be tripped out by the test.

Alarm level switch: recommended initial setting is 5 Megohm; however if still in alarm at 1 Megohm, call for service!

SPECIFICATIONS

Control voltage	115/220V AC + 20 -40% 50/60 Hz + 10%, 3VA
Max. Line voltage	600V AC/DC
Isolation voltage	24 - 600V AC/DC
Isolation time	0.5 ms
Measuring current	50µA max.
Contacts rating	250V 5A AC resistive
Dimensions	4.4" x 1.77" x 2.67" 112 x 45 x 68 mm

Available for DC control, 400Hz and different settings – consult factory

NOTE: DISCONNECT CONTROL POWER FROM THE STARTER ENCLOSURE IF HIGH VOLTAGE INSULATION TEST IS REQUIRED.